

# PM-3000-A

## PRODUCT ROLLING MACHINE

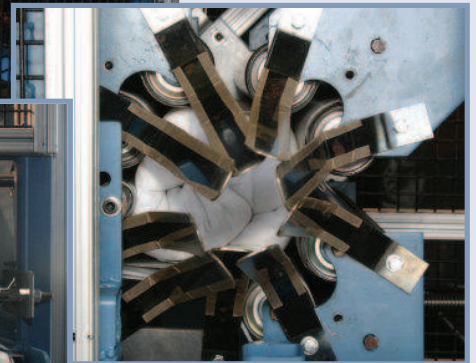

SINCE 1947

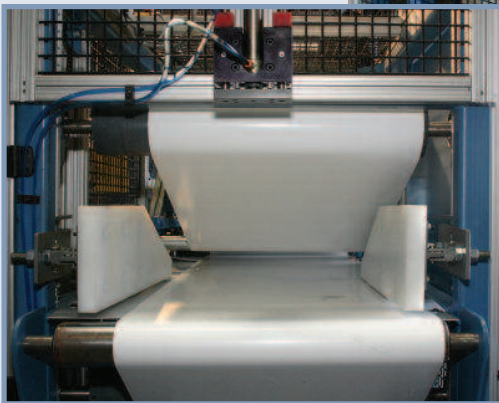

### OVERVIEW:

ABM International, Inc. has spent many years perfecting rolling machines for various products. The PM-3000-A can be manufactured to roll pillows, blankets, mattress pads, cushions and much more. The customer can specify the length, width, thickness, and desired roll diameter of the product to be rolled and ABM will manufacture a rolling machine that is right for the job. This robust design incorporates conveyor belts for compression and continuous feed, while providing for high production and consistent rolling. After the product is rolled, it is automatically ejected either into bags, cardboard sleeves, or boxes.

### FEATURES AND BENEFITS:

- ▶ Any desired width and length available. Standard pillow machine is just 18" wide
- ▶ Automatic conveyor feed
- ▶ Adjustable product guides
- ▶ Adjustable product rolling diameter standard pillow machine 6" - 10"
- ▶ Manual and Automatic ejection cycles
- ▶ Automatic length adjustment

## QUALITY

- ▶ ABM International, Inc. is a vertically integrated manufacturer with in-house design, programming, welding / fabricating, machining and assembly.
- ▶ With over 55 years of experience in manufacturing packaging machines, our highly trained expert staff consistently delivers the quality our customers deserve.

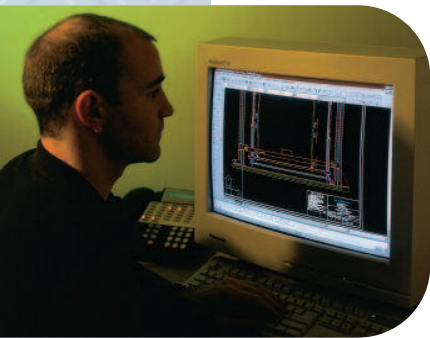

## IN-HOUSE MACHINE DESIGN

- ▶ ABM's highly trained engineering design team anxiously awaits your projects.
- ▶ We are available 24 hours a day for customer service, so you can rest well at night!

## TECHNICAL DATA

- ▶ Machine weight 950 lbs
- ▶ 220 volt three phase 50/60 cycle
- ▶ 15 Amps
- ▶ 100 PSI Air pressure

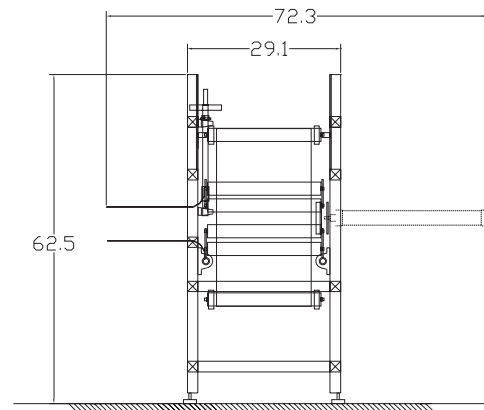
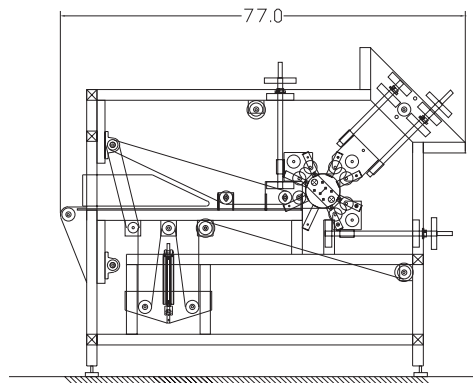

## ABM INTERNATIONAL, INC.

18209 Chisholm Trail, Suite #110  
Houston, Texas 77060  
Telephone: (281) 443-4440 Fax: (281) 443-4404  
[www.abminternational.com](http://www.abminternational.com)



SINCE 1947

ABM International, Inc., headquartered in Texas, has been serving the home furnishing market of the textile industry for over 55 years.

At ABM International, Inc. we are committed to manufacturing excellence and superior customer service. Let us provide you with the highest quality state-of-the-art machinery that will enhance your operations, improve your production, reduce your costs—and ensure your success!



# PM-3000A

Pillow Rolling Machine: Electro-Pneumatic  
[www.abminternational.com](http://www.abminternational.com)

- ◆ Installation instructions
- ◆ Operational guide
- ◆ Troubleshooting guide
- ◆ Parts list





# Table of Contents



- ◆ Section 1.0 - Safety
- ◆ Section 2.0 - Machine Set-up
- ◆ Section 3.0 - Machine Operation
- ◆ Section 4.0 - Troubleshooting Guide and Notebook
- ◆ Section 5.0 - Parts List

**TABLE OF CONTENTS:**

Introduction

Section 1.0 – Safety

Section 2.0 - Machine Setup

Section 3.0 – Machine Operation

Section 4.0 – Troubleshooting guide and notebook

Section 5.0 – Parts List

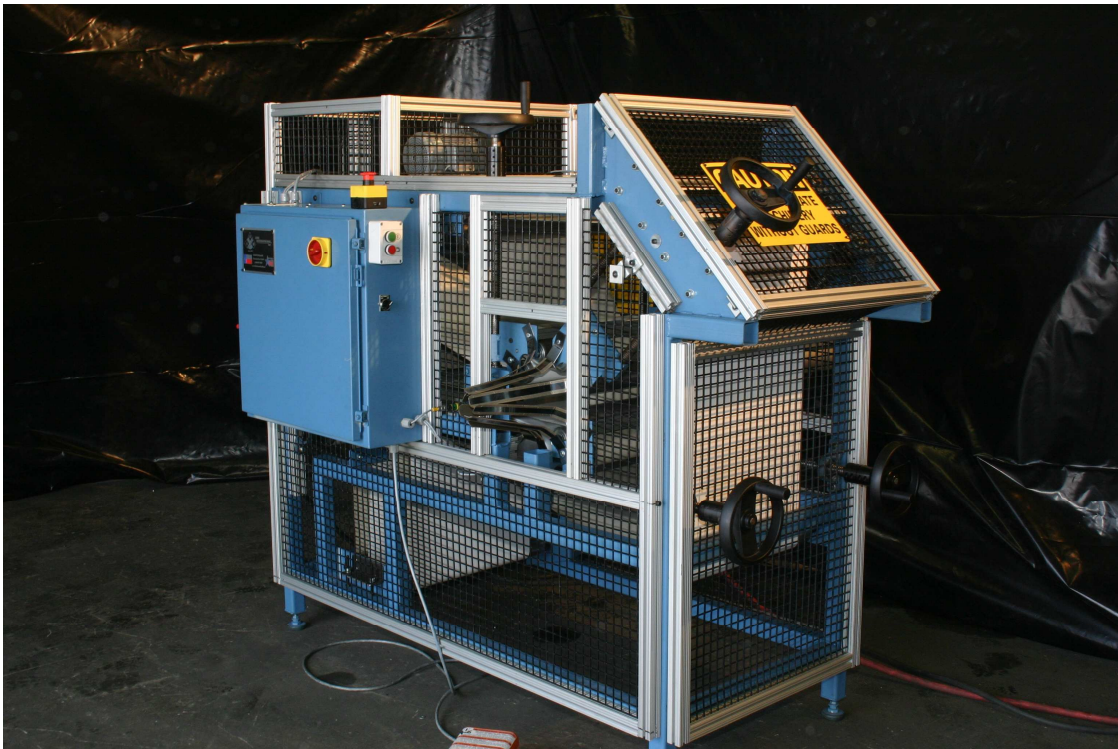

Figure 0.1 – PM-3000A`

**Introduction**

ABM International would like to thank you for the purchase of a PM-3000A Pillow Rolling Machine. ABM is confident that this machine will meet or exceed your expectations for cost, speed and durability.

If at anytime you experience problems with any of your ABM machines we ask that you contact us - 24 hours a day by calling our service department at (281) 443-4440. We can help you solve the problem quickly, and correctly. Your calls, questions, and comments will in turn help us to perfect the quality of our products and services in the future.

Once again, we thank you for your purchase.

Very truly yours,

ABM International, Inc.

Joe Podolski  
Vice President  
Engineering Department

## **Section 1: Safety**

### **1.0 Safety Introduction**

As with the operation of all machinery, safe operation of the PM-3000A is a major concern of ABM International, Inc. The purpose of this section is to inform personnel of the safe and prudent operation of a PM-3000A.

We have attempted to recommend the most effective methods and calculations to warn against actions that could result in personal injury, or make equipment unsafe. It is important to understand that ABM cannot anticipate, or list all conceivable safety methods and warn of all the possible hazards. In the interest of promoting safety, ABM advises that the operating personnel should always make sure that personal safety and the safe operation of the machine will not be adversely affected by their actions.

It is imperative that the operating personnel of the PM-3000A read and understand the information in this manual before operating the machine.

### **1.1 Safety Policy Statement**

The conservation of the assets of any company, which include the buildings, equipment, supplies and inventories as well as personnel, must be and is the responsibility of all levels of management. The purpose of a personnel and property conservation program is to insure that all phases of management recognize that personnel and property conservation are both inseparable parts of a company's objective...to produce quality products at the lowest possible cost.

Safety of personnel in every aspect must be of first consideration. The implementation of a conservation program will eliminate human suffering and effectively lower the direct and indirect costs resulting from employee injury. It will substantially reduce the exposure and probability of damage and / or loss of company's physical assets.

### **1.2 Safety Practices**

The safety factors must be observed to ensure safe operation of the PM-3000A.

1. Read and understand the operating instructions of the PM-3000A before operating.
2. Use extreme caution when working around the PM-3000A electrical controls.
3. Keep hands or other body parts away from the moving parts of the PM-3000A.
4. Wear appropriate personal safety protection.
5. Stop the PM-3000A immediately at any sign of malfunction or danger.
6. Do not crawl under or into the PM-3000A for any reason during the operation of the machine.
7. Do not reach into the PM-3000A at any time during the operation of the machine.
8. Do not climb, walk, or stand on the PM-3000A at any time.
9. Do not tamper with factory installed guards and or safety devices.

**Safety Practices Continued:**

10. Never operate machinery without all ABM installed guards and safety devices intact, and in working order.
11. Before starting the PM-3000A, ensure that no loose tools, bars or parts are lying in or on any part of the machine.
12. Proper fire fighting equipment should be kept in good operating condition and kept near in the event of fire.
13. Never attempt to service any of the pneumatic components until the unit is relieved of all air pressure.
14. Do not wear loose clothing or jewelry when operating the PM-3000A.
15. Always keep hair from coming in contact with moving parts.



## **SECTION 2.0 – Machine Setup**

The PM-3000A ships fully tested ready to operate. As a result, this manual provides a section on machine setup so that you can install the machine. Please read this manual in its entirety and follow all ABM instructions, especially the inspections. Total setup time, less power and air hook-up, should take approximately 1 hour.

### **SETUP INSTRUCTIONS:**

**INSPECTION #1:** Upon receipt of the machine, check to ensure that there is no visible damage. Figure 0.1 and the front cover of this manual are enough for this inspection.

**Note: that some components may be in different locations depending on the version of the machine.**

Determine the location in your facility for the compression machine. Level and position the machine in the desired location. Though not required, ABM recommends that the machine be bolted to the floor. Place the foot operated pedal in front of the machine on the floor. Once a final position has been determined for the foot pedal, coil any excess cable and wire tie it to the machine, which will reduce the risk of a tripping hazard.

Run a 220VAC 3 phase line (10 AMP) to the machine location. ABM does not recommend the use of any type of extension cord to power the machine. As with any machine, power should be run through approved conduit and ducting with proper termination. ABM does not supply a main power disconnect with the machine and recommends that the customer install one. You should have a licensed electrician connect the power to the machine at this time.

Plumb the machine with an air line capable of at least 100psi. ABM recommends that an air line of no less than 1/2 inch diameter be used for supply air. **NOTE: DO NOT CONNECT AIR TO MACHINE YET. UNTIL PROPER ELECTRICAL FUNCTION IS CONFIRMED. CONNECTING POWER AT THIS TIME CAN POSSIBLY RESULT IN INJURY.**

**INSPECTION #2:** Will confirm that the electronics of the rolling machine are functioning properly.

**WARNING: ELECTRICAL SHOCK HAZARD. THIS INSPECTION WILL REQUIRE POWER TO BE ON WHILE THE ELECTRONICS CABINET IS OPEN. IF A PROBLEM IS FOUND, YOU SHOULD NOT ATTEMPT TO REPAIR IT WITH THE POWER ON. DISCONNECT THE MACHINE PRIOR TO ADJUSTING ANY COMPONENTS WITHIN THE ELECTRICAL CABINET.**

Step one; open the electronics cabinet located on the side of the frame of the machine. The internals of the cabinet will look like Figure 2.0. From left to right the components are as follows: *Top row:* 24VDC Power Supply, PLC, Variable frequency drive, Fuse block, - *Bottom Row:* Input terminal, Output terminal, E-stop terminal.

*Vertical Column:* Disconnect, Fuses, Power Distribution Block, Contactor. With the power turned on, the 24Vdc power supply should have a green LED marked DC ON illuminated. If the green light is not on, check the main power connection and check that the main disconnect is on.

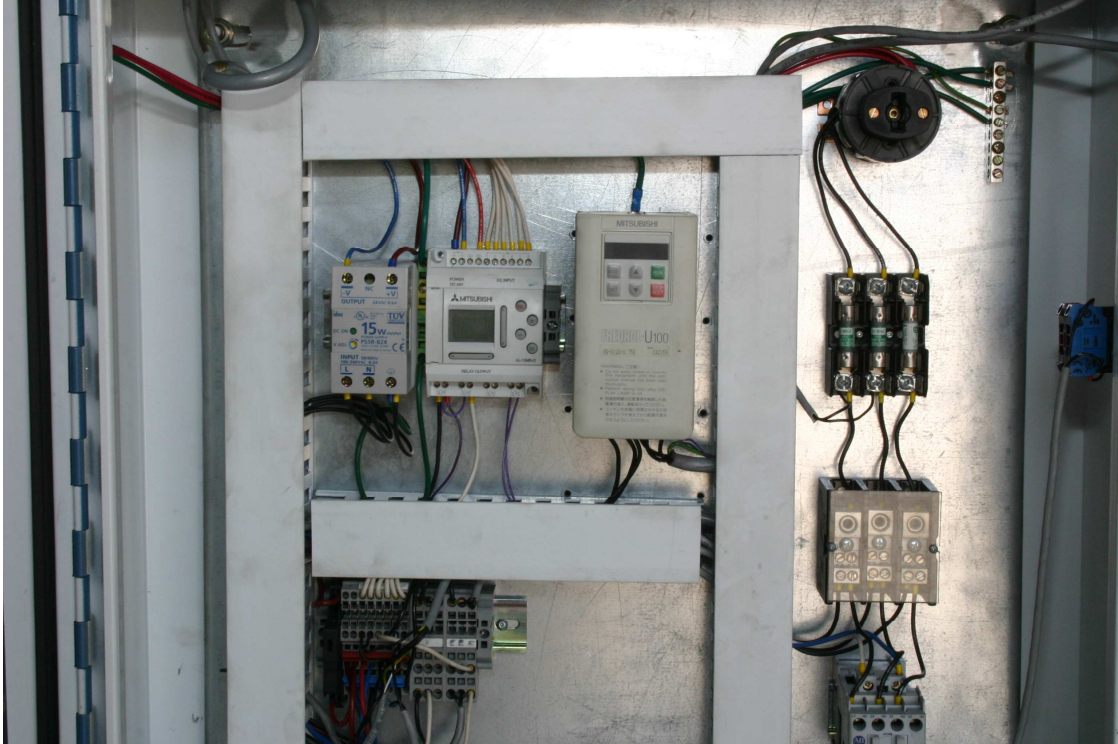

Figure 2.0 – Electrical Panel.

Upon power up, the PLC screen should have a few flashing symbols and two rows of circles visible, this is the function screen of the PLC. If a different screen is visible, repeatedly press the ESC button on the PLC until this screen appears. If text is not visible on the PLC, check the incoming 24Vdc from the power supply. The PLC power terminals are marked with a + and – sign located on the top terminal strip.

When the PLC displays the function screen, the inputs and outputs can be tested. The PLC screen should now have a top row of six (6) circles with the letter I at the beginning (this is the input row). The lower row should have four (4) circles with the letter O at the beginning (this is the output row). A solid, dark circle means the input/output is on and a clear circle means the input/output is off.

**INPUT INSPECTION:** Depress and release the red E-stop button located on the backside of the machine and main cabinet to ensure the PLC is reset to the beginning of the operation cycle. The third circle from the left on the input row (input #3) should be the only circle that is darkened. Depress and release the red E-stop button while watching the PLC screen. The second input should turn off and then back on when the button is released (this is the E-stop input). Depress and release the start button. Various inputs and outputs will illuminate, but only concern yourself with the input row at this moment. When the start button is depressed, the first circle (input #1) should darken.

When the start button is released, the input should shut off. Depress the red E-stop button to reset the machine. Press the stop button, the second circle should darken. Release the stop button and the second circle will shut off.

**OUTPUT INSPECTION:** Depress and release the red E-stop button located on the top of the machines cabinet to ensure the PLC is reset to the beginning of the operation cycle. At this time none of the four (4) circles in the lower row should be dark. Depress and release the start button once. The third & fourth circle of the lower row (output #3 & 4) should darken and the variable frequency drive will start. Press the stop button and the system will reset to stand-by.

If both the inputs and outputs have checked out, the electronics cabinet should be securely closed.

**FINAL TEST:**

**WARNING – WHEN CONNECTING AIR TO THE MACHINE, YOU MUST ENSURE THAT THERE ARE NO LOOSE ITEMS SUCH AS TOOLS FOOD DRINKS ETC. ON THE MACHINE AND THAT ALL PESONNEL ARE CLEAR OF THE MACHINE.**

The machine is now ready for the air connection. Adjust the pressure regulators so that a pressure reading of 40-100 psi is visible for the ejection cylinder and 95-100 psi is visible for the belt tension regulator.

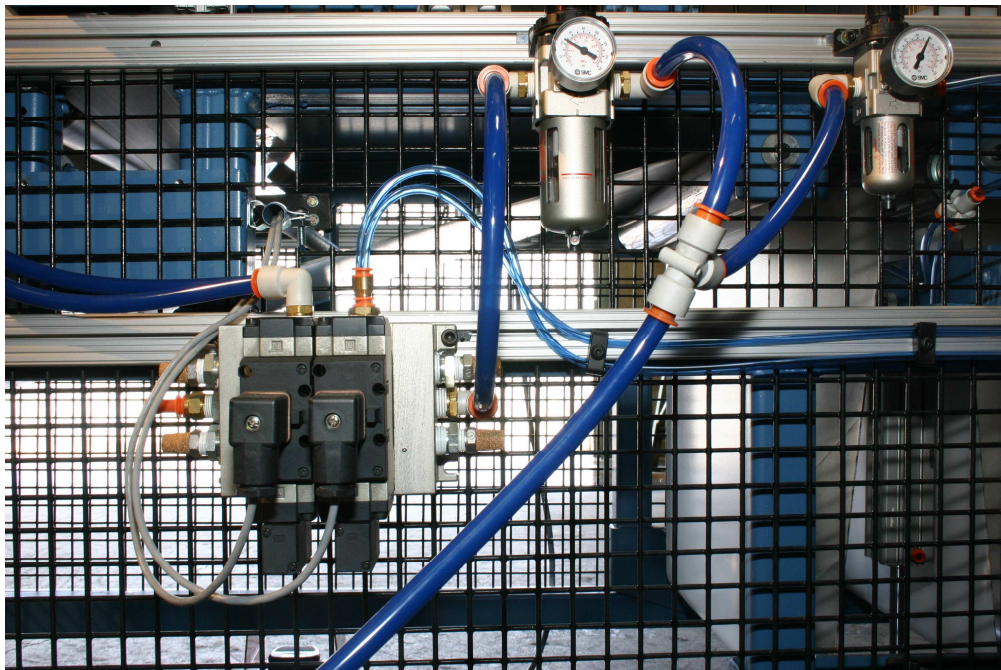

Figure 2.1 – Pressure regulators

### **SECTION 3.0 – Machine Operation**

This section will discuss how to properly use the PM-3000A to roll all of your pillows.

The PM-3000A is equipped with an automatic mode and a manual mode (see figure 3.1). While in manual mode the operator has control of the ejection process. With the machine in automatic mode, the pillow will be automatically ejected every time one is rolled up.

**CAUTION:** Make sure the operator keeps all their body parts out of the machine in automatic mode or accidental injuries may occur. This machine can be positioned in-line with a conveyor for feeding. When doing so make sure all pillows coming down the line are relatively parallel to the machine.



Figure 3.0 – Operator Start Station.





Figure 3.1 – Adjustable pillow rolling handles.

### **Adjustable handles**

There are four (4) adjustable handles for tuning the machine. Each 360 degree rotation of a handle executes a .2 inch move in rolling diameter or belt tracking. For inward movement turn handles counter clockwise, for outward movement turn handles clockwise. All four handles are used for increasing or decreasing the diameter of the roll.

The front two hand-wheels located at the lower front section of the machine are utilized for belt tracking. Turn only the left handle slightly either clockwise or counter clockwise depending on the position of the belt and the belt will center itself. The left handle is the closest to the pillow ejection horn.





Figure 3.2 – PM3000A at start of cycle

**Basic Operation: (Operator instructions)**

Step 1: Insert a pillow at the rear of the machine. The pillow will convey into the rolling area and will be rolled up. Then the conveyor will stop.

Step 2: Make sure all body parts are clear of machine.

Step 3: Slip a bag over the filling horn and press the ejection foot pedal. The packaged product will be ejected into the operators hands.

Step 4: Remove the packed good; from the machine and repeat the process again.

## **SECTION 4.0 – Troubleshooting guide**

This section is included to help diagnose and solve any problems that may occur with the PM-3000A. ABM has done its best to include as much information as possible.

However, not all problems are listed, therefore ABM asks that whenever a problem occurs you contact a service technician at our home office. To reach service dial 281-443-4440 and ask for a service technician, they are on call 24 hours a day, seven days a week.

### **Electrical power:**

The PM-3000A runs on a 10amp, 220VAC three phase supply line. The PLC, inputs and outputs (valves) run on 24Vdc produced by the power supply found in the cabinet. The PLC has its' incoming power fused through a terminal block found inside the cabinet. A fuse with a 1/2A rating is standard.

### **Verifying inputs and outputs:**

Table 4.0 lists the inputs and outputs, their location on the PLC and their normal wired condition.

<b>Description</b>	<b>PLC location</b>	<b>Wired Condition</b>
Start	Input #1	Normally Open (N.O.)
Stop	Input #2	Normally Open (N.O.)
E-Stop	Input #3	Normally Closed (N.C.)
Pillow sensor	Input #4	Normally Open (N.O.)
Foot pedal	Input #5	Normally Open (N.O.)
Automatic mode on/off	Input #6	Normally Open (N.O.)
Ejection cylinder	Output #1	Normally Open (N.O.)
Pillow stop cylinder	Output #2	Normally Open (N.O.)
Not used	Output #3	Normally Open (N.O.)
Conveyor motor on/off	Output #4	Normally Open (N.O.)

Table 4.0 – PLC inputs and outputs.

To verify that an input or output is functioning properly, the PLC displays a status screen of the I/O. To enter the status screen, depress the escape button until a screen with two rows of circles is displayed. The top row of six (6) circles, marked with a letter I, displays the inputs. A darkened in circle signifies the input is on; a clear signifies the input is off. Depressing either the foot pedal or E-stop will cause their corresponding input to turn on and off. Outputs function the same way, if a circle in the lower row is darkened in; the output is on.

**Pneumatic systems:**

The pneumatic system of an ABM PM-3000A is very straightforward. The system consists of a valve block with four (2) valves, a cylinder for ejection, one (1) cylinder for pillow entrance, (2) cylinders for belt tensioner and two (2) filter/regulator combo units.

Valve block: a device used to distribute air to multiple valves from a common location. The valve block on the PM-3000A has two (2) valves with individual communication to the PLC.

Valve (individual): A valve is a device found on the valve block that is operated individually through the PLC. It is possible to manually cycle an individual valve by depressing the small orange button located directly on the valve. A small screwdriver or a pen may be needed to depress the button properly. Removal of a valve for service is accomplished by loosening the small socket head cap screw located directly above the valve, and gently pulling the valve out away from the manifold. Installation is made by reversing the above procedure.

Cylinders: Some cylinders are uneconomical to repair and thus any damage that may occur to a cylinder should be rectified by replacing the cylinder. Others have low cost repair kits available from ABM.

Quick exhaust valves (optional): These valve are mounted directly to the cylinder ports. They allow the cylinders to move more quickly by exhausting the air inside the cylinder faster than the main manifold can. The machine can operate normally with or without the valves installed.

Filter/regulator combo unit: The combo unit is the machines last line of defense against foreign materials (water, steel particles, etc.) found in pneumatic lines. The machine can be run without a combo unit but serious damage can occur to the valve block and cylinders. The combo unit also performs the task of regulating the incoming air pressure. Air pressure on both the ejection and belt tension cylinders is individually adjustable. Pressures should be set according to machine demand. Excessively high or low pressures may cause the machine to function improperly.

**Troubleshooting notes:**

A few blank pages are provided so that you and your personnel can keep records and notes of machine problems. By using this section and keeping it attached to the manual, you will always have your own personalized quick reference repair section.

TROUBLESHOOTING NOTES:

Date	Problem	Solution

TROUBLESHOOTING NOTES:

Date	Problem	Solution



**SECTION 5.0 - PARTS LIST**

This section lists the ABM part numbers needed to order any part on the PM-3000A. ABM carries all of the components below in stock at all times (unless noted with an \* next to the number in the quantity column). Non-stock items can usually be shipped within 2-3 days however some custom cylinders and mechanical components can take as long as 2-3 weeks to manufacture. Any order for stock parts placed before 5:00 P.M. C.S.T. can be shipped the same day for next or second day delivery. The parts/service department can be reached at (281) 443-4440. As with any machine, buying the correct parts from the correct manufacturer will allow your machines to operate at their best. Buying parts from sources other than ABM will void your warranty.

**ABM International, Inc.**

**#9000 PILLOW ROLLER ORDER SHEET**

**220 / 3 Phase 60Hz - 10A  
100 PSI**

<u>Qty</u>	<u>Item Description</u>	<u>ABM Part #</u>
<b><u>COMMERCIAL COMPONENTS</u></b>		
4	Hand Wheel	C-9000-001
1	2" Wide PTFE Tape	C-9000-002
2	Pusher plate, Guide Plate	C-9000-003
4	Small mounts	C-9000-004
14	1-1/4 x 0.090 SPRING STEEL x 30'	C-9000-005
1	45 Degree Acme Bearing Plate spacer	C-9000-006
2	Conveyor Roller Plate Spacer	C-9000-007
4	Upper/Lower Conveyor Belt Tension Beam	C-9000-008
2	Pusher cylinder beam	C-9000-009
1	Conveyor motor mount beam	C-9000-010
1	Door Handle	C-9000-011
2	Door Hinge	C-9000-012
5	Wire mesh retainer	C-9000-013
3	2-hole plate	C-9000-014
4	2-hole inside corner bracket	C-9000-015

**DRIVE TRAIN COMPONENTS**

12	1" Pillow Block	D-9000-400
4	1-3/8" Conveyor Roller	D-9000-500
18	2-1/2" Conveyor Roller	D-9000-501
2	4" Conveyor Roller	D-9000-502
6	Size change sprocket	D-9000-600
6	Size change sprocket taper bushing	D-9000-601
1	Conveyor motor sprocket	D-9000-602
2	Conveyor roller sprocket	D-9000-603
2	Idler Sprocket	D-9000-604
1	Lower Conveyor Belt	D-9000-700
1	Upper Conveyor Belt	D-9000-701
1	Pusher Piston Belt	D-9000-710
30	#35 Chain	D-9000-800
4	Two piece solid shaft coupling	D-9000-900
6	Threaded rod	D-9000-901
8	Coupling Nut	D-9000-902

**ELECTRICAL COMPONENTS**

1	Enclosure	E-9000-001
1	Power Interlock	E-9000-002
1	Power Distribution Block	E-9000-003
1	Distribution block plastic cover	E-9000-004
1	FRN-R fuse block	E-9000-005
3	10 Amp Fuse	E-9000-006
1	Contactora 24VDC Coil	E-9000-007
1	Power supply 24VDC	E-9000-008
1	1/2 Amp Fuse	E-9000-008
1	Ground bar - 6" long	E-9000-009
1	PLC controller	E-9000-010
1	Inverter drive	E-9000-011
1	2 Button enclosure w/ buttons - Start/Stop	E-9000-100
1	On/Off black toggle switch	E-9000-400
1	Photo sensor	E-9000-500
2	Mushroom head push button station	E-9000-600
1	Gear Motor	E-9000-700
1	Quick disconnect cable	E-9000-800
1	Reflective tape	E-9000-900
5	1/2" Liquid-Tite Conduit fittings	E-9000-901
2	DIN Rail	E-9000-902
1	Fuse holder	E-9000-903
8	Sensor terminal blocks	E-9000-904
6	Output terminal blocks	E-9000-905
1	Ground Block	E-9000-906
4	Terminal end block	E-9000-907
1	Wire duct	E-9000-910
1	Wire duct cover	E-9000-911
1	1/2" conduit	E-9000-912
2	1/2" conduit clamp	E-9000-913

**PNEUMATIC COMPONENTS**

1	Air cylinder for pusher	P-9000-001
2	Conveyor Belt Tension Cylinder	P-9000-002
1	Pillow stopper cylinder	P-9000-003
2	Double Rod clevis kit	P-9000-004
4	Clevis kit for Guide plates	P-9000-005
1	Manifold	P-9000-010
2	Valve	P-9000-011
1	Regulator/Filter Combo Unit (For valve block)	P-9000-800
1	Regulator/Filter Combo Unit (For tension cylinder)	P-9000-801
1	Regulator bracket	P-9000-802
2	Regulator gauge	P-9000-803
6	1/4 tube x 1/8 NPT Elbow	P-9000-900
2	1/4 tube x 3/8 NPT Elbow	P-9000-901
2	1/2" Tube x 3/8 NPT Elbow	P-9000-902
16	1/4" Blue hose	P-9000-910
6	1/2" Blue Hose	P-9000-911



1) CONNECT H1 TO H3 AND H2 TO H4 FOR 230 VAC LINE.

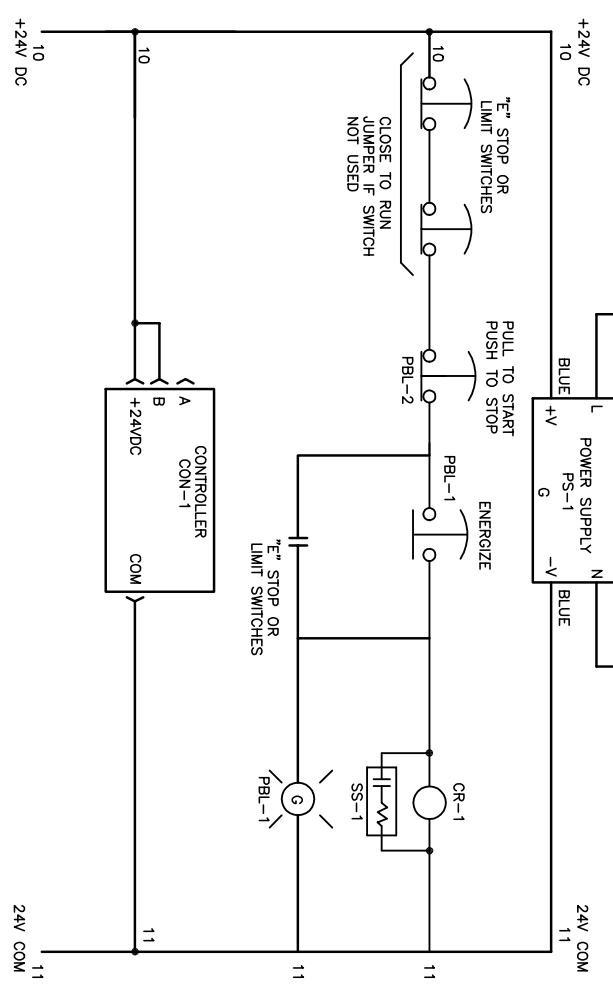
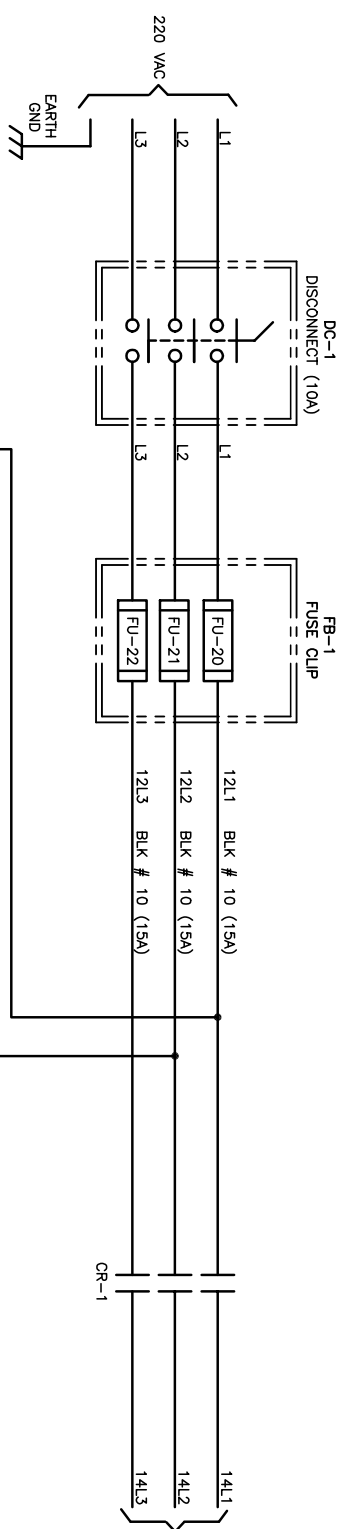

<b>INCHES</b>		<b>ABM</b>	
UNLESS OTHERWISE SPECIFIED		INTERNATIONAL	
DO NOT SCALE DRAWING		211 SERRYS AVE.	
ALL DIMENSIONS ARE IN INCHES		EATON SQUARE VALVE, L. 60007	
ALL DIMENSIONS ARE TO CENTER UNLESS NOTED OTHERWISE		SCHEMATIC WIRING POWER	
ALL DIMENSIONS ARE TO CENTER UNLESS NOTED OTHERWISE		PILLOW ROLLER	
ALL DIMENSIONS ARE TO CENTER UNLESS NOTED OTHERWISE		DATE: 6/28/05	
ALL DIMENSIONS ARE TO CENTER UNLESS NOTED OTHERWISE		DRAWN BY: J. BODOLSKI	
ALL DIMENSIONS ARE TO CENTER UNLESS NOTED OTHERWISE		CHECKED BY: J. BODOLSKI	
ALL DIMENSIONS ARE TO CENTER UNLESS NOTED OTHERWISE		SCALE: FULL	
ALL DIMENSIONS ARE TO CENTER UNLESS NOTED OTHERWISE		SHEET NO. 1	
ALL DIMENSIONS ARE TO CENTER UNLESS NOTED OTHERWISE		TOTAL SHEETS 1	
ALL DIMENSIONS ARE TO CENTER UNLESS NOTED OTHERWISE		DRAWING NO. E-9000-100	



# INPUTS

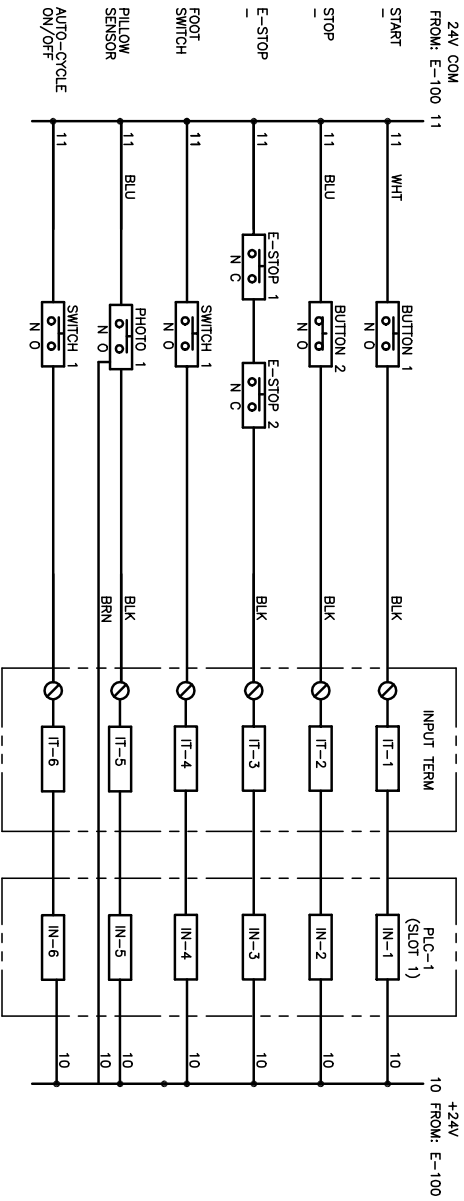

# OUTPUTS

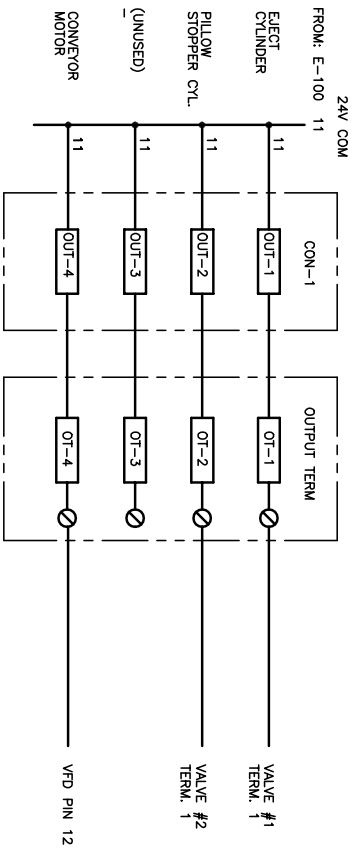

NOTE: VALVE TERMINAL BLOCK WIRE TERMINAL #2 TO +24VDC AND TERMINAL #3 TO COMMON. TERMINAL #1 AND GND ARE NOT USED.

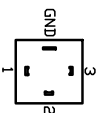

**INCHES**  
UNLESS OTHERWISE SPECIFIED

**ABM**  
INTERNATIONAL

211 SERRIS AVE.  
BLK GROVE VALLEY, IL 60007

SCHEMATIC: INPUTS, OUTPUTS  
PILLOW ROLLER

DESIGNED BY: JOE RODOLSKI  
DATE: 5/28/76

B SIZE 1 1 E-9000-101

REF: E-100  
14L1  
14L2

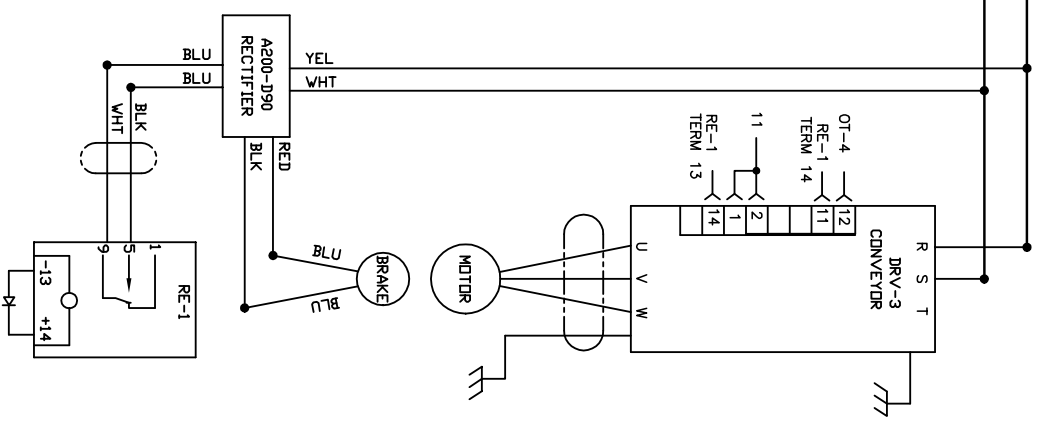

NOTE: DIODE RECT TO PROTECT VFD OPEN COLLECTOR OUTPUT. MINIMUM PIV 50 VOLTS.

<b>INCHES</b>		<b>ABM</b>	
UNLESS OTHERWISE SPECIFIED		INTERNATIONAL	
DO NOT SCALE DRAWING		211 SERRYS AVE.	
ALL DIMENSIONS ARE IN INCHES		EATON GROVE MILWAUKEE, WI 53007	
ALL DIMENSIONS ARE TO CENTER UNLESS NOTED OTHERWISE		SCHEMATIC WIRING	
ALL DIMENSIONS ARE TO CENTER UNLESS NOTED OTHERWISE		PILLOW ROLLER	
ALL DIMENSIONS ARE TO CENTER UNLESS NOTED OTHERWISE		DATE: 6/28/05	
ALL DIMENSIONS ARE TO CENTER UNLESS NOTED OTHERWISE		DRAWN BY: JOE PODOSKI	
ALL DIMENSIONS ARE TO CENTER UNLESS NOTED OTHERWISE		CHECKED BY: -	
ALL DIMENSIONS ARE TO CENTER UNLESS NOTED OTHERWISE		MATERIAL: 9000	
ALL DIMENSIONS ARE TO CENTER UNLESS NOTED OTHERWISE		SHEET NO.: 1	
ALL DIMENSIONS ARE TO CENTER UNLESS NOTED OTHERWISE		TOTAL SHEETS: 1	
ALL DIMENSIONS ARE TO CENTER UNLESS NOTED OTHERWISE		SCALE: FULL	
ALL DIMENSIONS ARE TO CENTER UNLESS NOTED OTHERWISE		DRAWING NO.: E-9000-102	